

F&eIT Series
Isolated Digital I/O Module
DIO-4/4(FIT)GY



* Specifications, color and design of the products are subject to change without notice.

Features

This product can perform 4-point digital signal input and 4-point digital signal output, treating 4 points as a group.

Input section is ready to accept both the current sinking output and current source output.

The output section is a high sink current, open collector type using high-capacitance transistors.
150 mA/24 VDC or 50 mA/48 VDC max. (per channel)

Isolated I/O operations using an optocoupler improves noise immunity.

A rotary switch allows you to set device IDs, making it easy to keep track of device numbers.

Like other F&eIT series products, the module has a 35mm DIN rail mounting mechanism as standard. A connection to a controller module can be effected on a lateral, stack basis in a unique configuration, which permits a simple, smart system configuration without the need for a backplane board.

Packing List

- Module[DIO-4/4(FIT)GY] ...1
- First step guide ... 1
- CD-ROM [F&eIT Series Setup Disk] *1...1
- Interface connector plug...1

*1 The CD-ROM contains various software and User's Guide.

This product is an expansion module (device module) that adds digital signal I/O interfaces to one of various types of controllers. The product is used in combination with the I/O controller module <CPU-CAx(FIT)GY> (*1) or microcontroller unit <CPU-SBxx(FIT)GY> (*1) in the F&eIT Series.

This product can perform a maximum of 4 points of Optocoupler isolated input and 4 points of Optocoupler isolated output per module. (Input: 12 - 24 VDC specified, output: 12 - 48 VDC specified)

*1 This module is available in different product models. "x" in each model number represents a blank or one alphanumeric character. This is applicable to the rest of this document.

Specification

Specifications

Item	Specifications	
	DIO-4/4(FIT)GY	
Input section		
Input format	Optocoupler isolated input (compatible with current sink output and current source output)	
Input resistance	3kΩ	
Input ON current	3.4mA or more	
Input OFF current	0.16mA or less	
Number of input signal points	4 points (4 points/common)	
Response time	Within 1msec	
External circuit power supply	12 - 24VDC (±15%) (4mA/12V - 8mA/24V per channel)	
Output section		
Output format	Optocoupler isolated open collector output (current sink type)	
Ratings	Output voltage	12 - 48VDC (±15%)
	Output current	150mA (12 - 24V) (per channel) (Max.) 50mA (36 - 48V) (per channel) (Max.)
Number of output signal points	4 points (4 points/common)	
Response time	Within 1msec	
External circuit power supply	12 - 48VDC (±15%)	
Common section		
Interrupt level	Using CPU-SBxx(FIT)GY: IRQ 5, 7, or 9	
Internal current consumption	5VDC(±5%) 150mA(Max.) *1	
Allowable distance of signal extension	Approx. 50m (depending on wiring environment)	
Physical dimensions (mm)	25.2(W) x 64.7(D) x 94.0(H) (exclusive of protrusions)	
Weight of the module itself	100g	
Module connection method	Stack connection by means of a connection mechanism standard with the system.	
Module installation method	One-touch connection to 35mm DIN rails (standard connection mechanism provided in the system)	
Applicable wire	AWG 28 - 16 wire type: 0.32 - 1.30mm	
Applicable plug	FRONT-MC 1.5/12-STF-3,81 (made by Phoenix Contact Corp.) 3.81mm-pitch, rated current: 8A (Max.)	

*1 The stack connector accepts currents of up to 3.0A (Max.).

Installation Environment Requirements

Item	Requirement description	
Operating temperature	0 - 50°C	
Storage temperature	-10 - 60°C	
Operating humidity	10 - 90%RH (No condensation)	
Floating dust particles	Not to be excessive	
Corrosive gases	None	
Noise immunity	Line-noise *1	AC line/2kV, Signal line/1kV (IEC1000-4-4Level 3, EN61000-4-4Level 3)
	Static electricity	Contact discharge/4kV (IEC1000-4-2Level 2, EN61000-4-2Level 2)
	resistance	Atmospheric discharge/8kV (IEC1000-4-2Level 3, EN61000-4-2Level 3)
Vibration resistance	Sweep	10 - 57Hz/semi-amplitude 0.15mm, 57 - 150Hz/2.0G
	resistance	80minutes each in X, Y, and Z directions (JIS C0040-compliant, IEC68-2-6-compliant)
Impact resistance	15G half-sine shock for 11ms in X, Y, and Z directions (JIS C0041-compliant, IEC68-2-27-compliant)	

*1 When using a POW-AD22GY

CAUTION

When connecting one of the modules to a controller module, the internal current consumption should be taken into account. If the total current exceeds the capacity of the power supply unit, the integrity of the operation cannot be guaranteed. For further details, please see the Controller Module manual.

Block Diagram

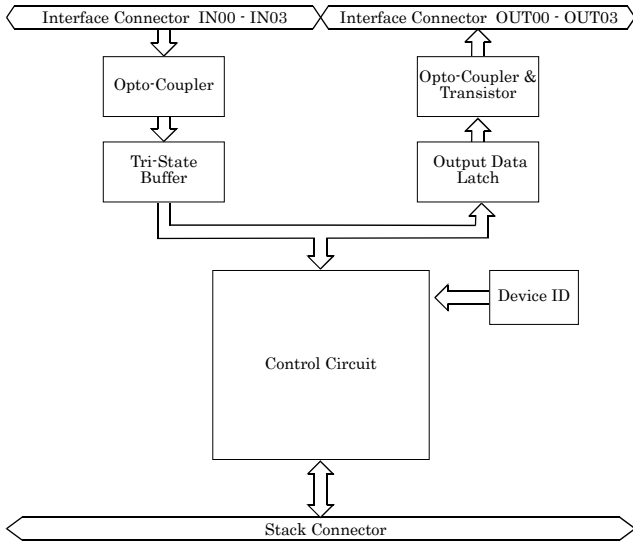

Physical Dimensions

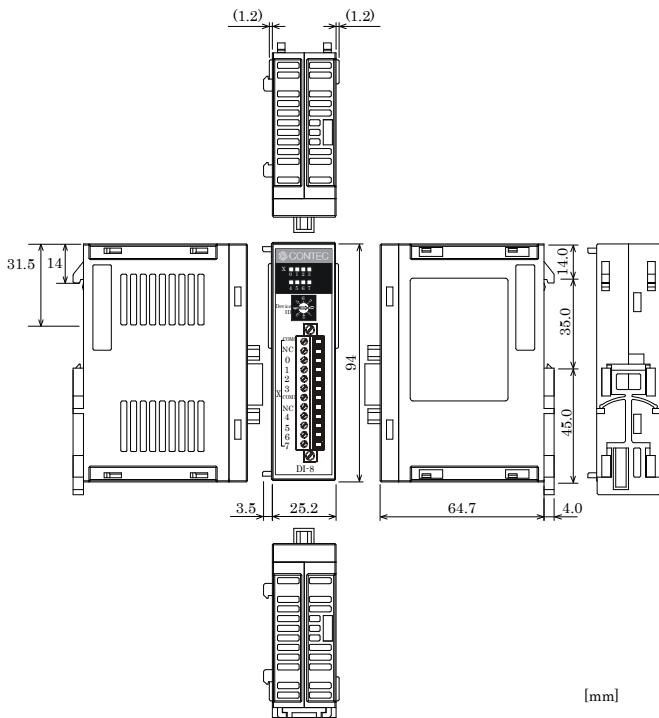

[mm]

Functions and control method by controller connected

This product can be connected to a variety of controllers.

Supported controllers

- Microcontroller Unit : CPU-SBxx(FIT)GY
- I/O Controller Module : CPU-CAxx(FIT)GY
- Monitoring & Control Server Unit : SVR-MMF2(FIT)
- Monitoring & Control Server Unit : SVR-MMF(FIT)GY

Check each controller to which the module can be connected as well as the method of controlling the module when connected to that controller.

Connections to controllers

O: Permitted
x: Not permitted

	CPU-SBxx(FIT)GY	CPU-CAxx(FIT)GY	SVR-MMF2(FIT)	SVR-MMF(FIT)GY
DIO-4/4(FIT)GY	o	o	o	o
DI-8(FIT)GY	o	o	o	o
DO-8(FIT)GY	o	o	o	o
Device ID setting range	0-7	0-7	0-7	0-7

Control method by controller connected

	CPU-SBxx(FIT)GY	CPU-CAxx(FIT)GY	SVR-MMF2(FIT)	SVR-MMF(FIT)GY
Control using the I/O address map	o			
Control using the memory address map		o		
Control via the Windows driver *	FIT Protocol	o		
	API-CAP(W32)		o	
	API-SBP(W32)	o		
Control over the web (as set from within the browser)			o	o

* The API-SBP(W32) is included in the development kit [DTK-SBxx(FIT)GY]; the other drivers are bundled with each controller.

Control using the I/O address map

When connected to the CPU-SBxx(FIT)GY, the module can receive I/O instructions directly from the controller module.

Control using the memory address map

When connected to the CPU-CAxx(FIT)GY, the module can be accessed from the host computer over the network. The module is assigned with its device ID in the memory managed by the controller module. The application running on the host computer controls the module by reading/writing the memory managed by the controller module.

Control via the Windows driver

For the functions and settings available when using the Windows driver, refer to the reference manual and online help for each module.

Control over the web

You can monitor collected data and manage the log over the web. You can use your familiar browser to easily make various settings. For details, refer to the reference manual for the SVR-MMF2(FIT), SVR-MMF(FIT)GY.

Interface Connector

How to Connect an Interface Connector

When connecting the Module to an external device, you can use the supplied connector plug.

To wire the Module, strip the sheath about 9 - 10mm from an end of the wire and insert the exposed wire into an opening. Tighten the screw to fasten the inserted wire. Applicable wires are AWG28 - 16.

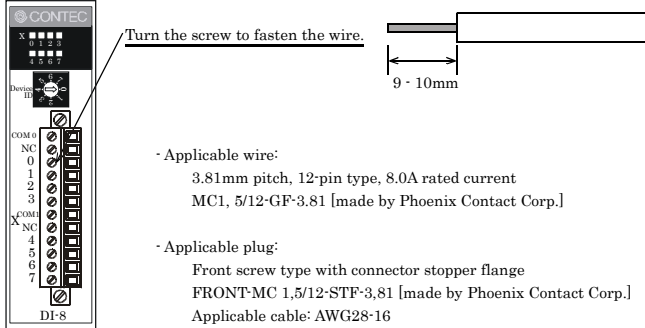

CAUTION

Removing the connector plug by grasping the cable can break the wire.

Signal Layout on the Interface Connector

The Module can be connected to an external device using a 12-pin connector that is provided on the Module face.

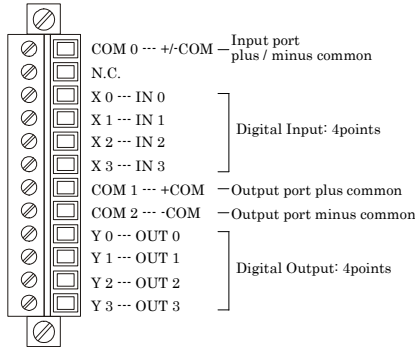

External I/O Circuits

Input section

Figure below shows the input equivalent circuit for the interface section of this product.

The signal input section consists of an Optocoupler isolated input (compatible with both current sink output and current source output). An external power supply is therefore required to drive the input section of this module. The power requirement for the <DIO-4/4(FIT)GY> or <DI-8(FIT)GY> is about 8 mA per input channel at 24 VDC (about 4 mA at 12 VDC).

Input Circuit

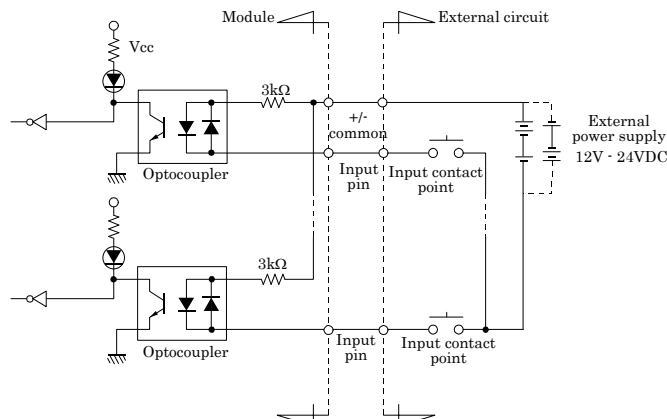

Example of a Connection to Current Sink Output

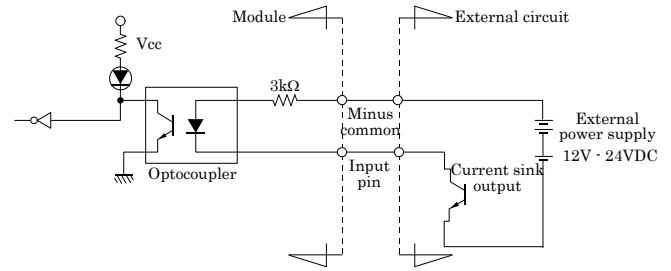

Example of a Connection to Current Source Output

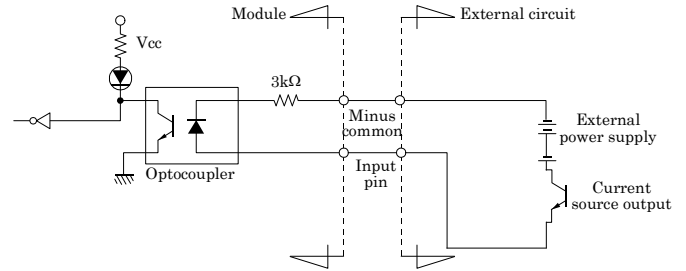

Output section

Figure below shows the output circuit for the interface section of this product. The signal output section consists of an Optocoupler isolated open collector output (current sink type). An external power supply is therefore required to drive the output section of this module.

The maximum output current rating per channel is 150 mA for this product (at 12 - 24 VDC) or 50mA for this product (at 36 - 48 VDC). A surge voltage protection circuit (zener diode) is provided for the output transistors of this module. When the module drives relays, lamps, and other induction loads, however, another surge voltage countermeasure should be provided on the load side.

CAUTION

When the power is turned on, all output will be OFF.

Output Circuit

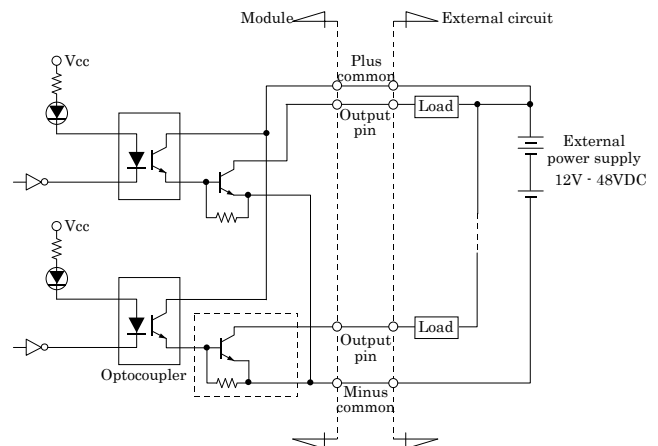

Connection example: Using Inputs X0

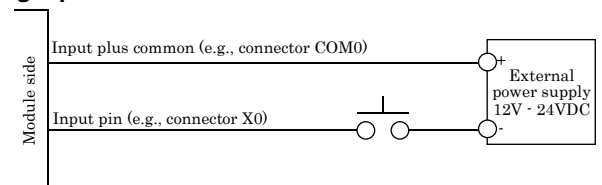

Using Outputs Y0

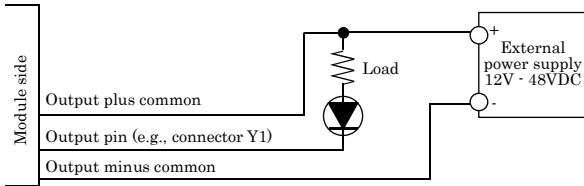

Example of Connecting Outputs and Inputs

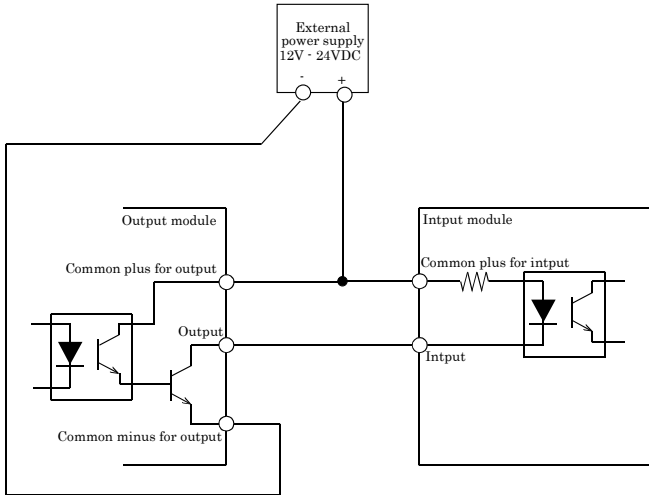

Setting a Device ID

The controller module distinguishes and keeps track of the modules that are connected to it by assigning device IDs to them. Each module, therefore, should be assigned a unique ID.

A Device ID can be assigned in a 0 - 7 range, so that a maximum of eight modules can be distinguished.

The factory setting for the Device ID is [0].

Setup Method

A Device ID can be set by turning the rotary switch that is located on the module face.

A Device ID can be assigned by turning the switch.

